

**ENERGIZER L522**  
Lithium

**9V**

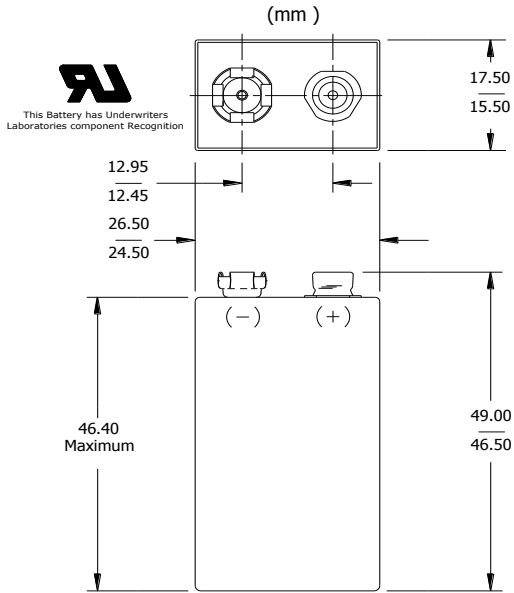

**Industry Standard Dimensions**



**Specifications**

|                            |  |
|----------------------------|--|
| <b>Classification:</b>     | Lithium 9V   |
| <b>Chemical System:</b>    | Lithium-Manganese Dioxide (Li/MnO <sub>2</sub> )                           |
| <b>Designation:</b>        | ANSI-1604LC  |
| <b>Nominal Voltage:</b>    | 9.0 volts  |
| <b>Operating Temp:</b>     | -40°C to 60°C  |
| <b>Storage Temp:</b>       | -40°C to 60°C  |
| <b>Max Discharge :</b>     | 1000 mA continuous   |
| <b>Safety Features:</b>    | Positive Temperature Coefficient Switch (PTC)<br>Burst Proof Venting Holes |
| <b>Typical Weight:</b>     | 33.9 grams   |
| <b>Typical Volume:</b>     | 21.4 cubic centimeters   |
| <b>Jacket:</b>             | Plastic Label  |
| <b>Terminal:</b>           | Miniature Snap   |
| <b>Shelf Life:</b>         | 10 Years   |
| <b>Typical Li Content:</b> | 1.35 grams   |
| <b>UL/UN Listed:</b>       | MH12454 / 38.3   |

**Milliamp-Hours Performance (21°C)**

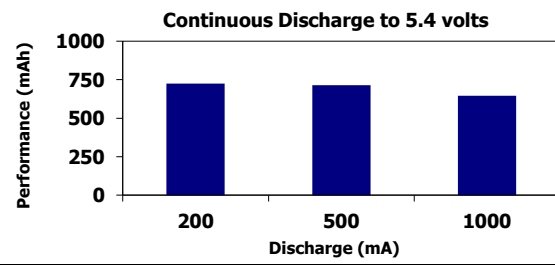
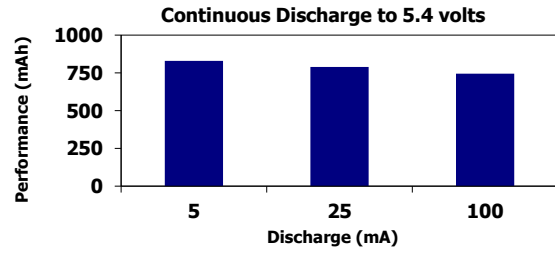

**Typical Discharge Performance (21°C)**

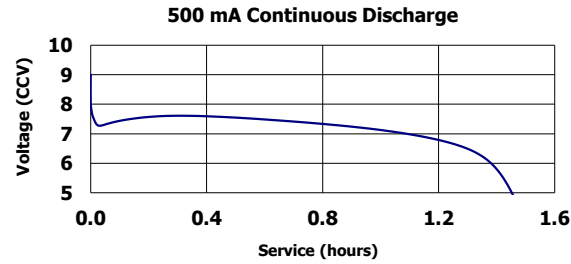
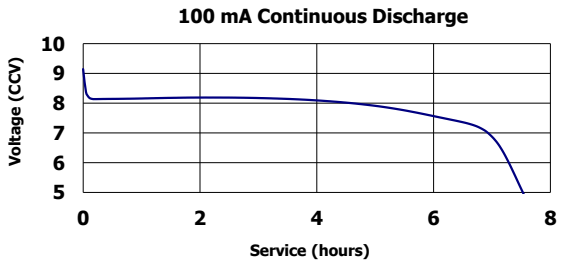
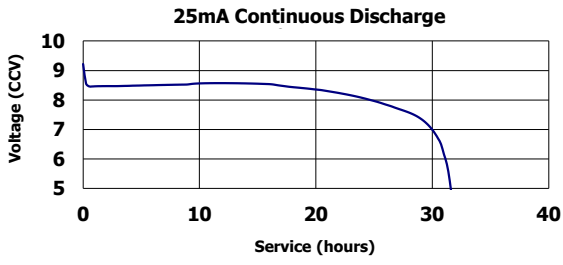

**Important Notice**

This datasheet contains typical information specific to products manufactured at the time of its publication.  
©Energizer Holdings, Inc. - Contents herein do not constitute a warranty.