

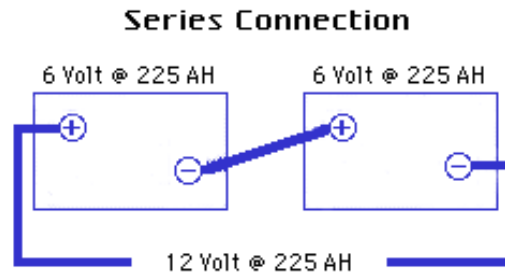

Connecting in Series (Increases Voltage)

In connecting batteries in series the positive terminal of the first battery is connected to the negative terminal of the second battery and so on down the string.

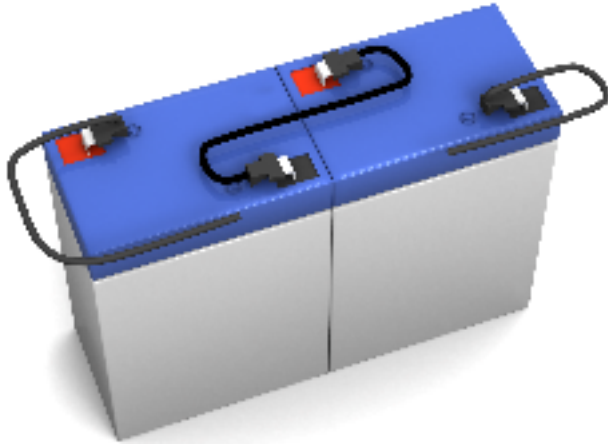

The interconnecting cables must be of equal length and resistance to insure equalization of the load. All batteries in the string will receive the same amount of charge current, though individual battery voltages may vary.

High voltage strings of batteries in series should be limited to twenty 6 volt or ten 12 volt batteries when a single constant voltage charger is connected across the entire string. Differences in capacity can cause some batteries to overcharge while others remain undercharged thus causing premature aging of batteries. It is, therefore, not advisable to mix batteries of different capacities, make, or age in a series string.

Connecting in Parallel (Increases Capacity)

When charging batteries in parallel (positive terminals are connected to the positive terminal and negative terminals to the negative), all batteries in the string will receive the same charge voltage but the charge current each battery receives will vary until equalization is reached.

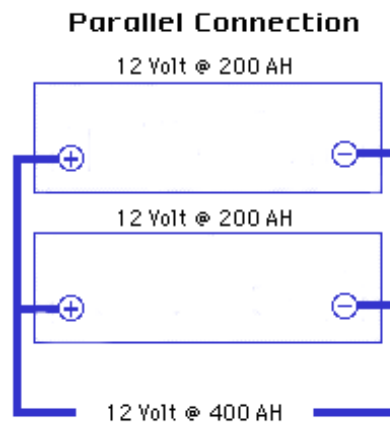
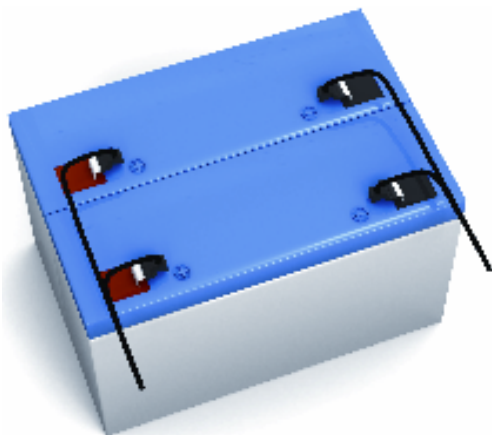

PLEASE REFER TO OUR TECHNICAL MANUAL PAGES 17 AND 18 FOR IMPORTANT INFORMATION ON CHARGING IN SERIES OR PARALLEL